

EH series

HITACHI

EH1700



DUMP TRUCK

- **Model Code** : EH1700-3
- **Nominal Payload with Standard Equipment** : 95.2 tonnes (104.9 tons)
- **Target Gross Machine Operating Weight** : 163 300 kg
- **Engine** : MTU Detroit Diesel 16V Series 2000
Rated Power 783 kW (1 050 HP)

Refined Engineering has Created Hauling Capability well Recognized in the Construction, Quarry, and Mining industry.



Hitachi Technologies

Hitachi Trucks, like Hitachi Excavators are designed and manufactured using cutting edge technology. Trucks designed by Hitachi using Hitachi Electronic devices result in great electrical system reliability, efficiency and control.



Fuel Efficient

The EH1700 uses the efficient 783 kW (1 050 HP) MTU Detroit Series 2000 engine, providing long life while optimizing performance and reliability. As well as fuel efficient, the engine fulfills the requirements of U.S. EPA Tier 2.



Long Frame Life

Frame rails are tapered from front to rear to distribute the load evenly over the entire length of the chassis. In place of castings, cold rolled steel is used as it is known to be more homogeneous and easier to repair. Weld joints are oriented longitudinally to the principal flow of stress for strength and long life. Proven design and manufacturing methods with state-of-the-art ultrasonic testing ensure a quality product.



Unique Body Design

The single sloped floor evenly distributes material shedding during dumping. A continuously exhaust-heated body reduces carry-back of material, and muffles exhaust. Horizontal floor and side rail stiffeners distribute load shocks evenly over the entire body length, minimizing stress concentrations in any one area. Closely spaced floor stiffeners reduce wear due to impact loading.



Well Matched: EH1700 & Excavators

Excavator	EX1900-6 (BH)	EX1900-6 (LD)	EX2500-6 (BH)	EX2500-6 (LD)
Boom	8.3 m Boom	-	9.0 m Boom	-
Arm	3.6 m Arm	-	4.2 m Arm	-
Bucket Capacity	*12.0 m ³	11.0 m ³	*15.0 m ³	15.0 m ³
Passes	4 or 5	5	3 or 4	3 or 4

BH: Backhoe LD: Loading shovel *SAE,PCSA heaped capacity

Rugged Construction



Technologically Advanced

The EH1700 is designed to develop low cycle times and extra efficiency in the heavy duty applications of quarrying and mining. This truck provides low operating costs, unparalleled productivity and overall quality through its superior structure and systems design.



Robust Frame

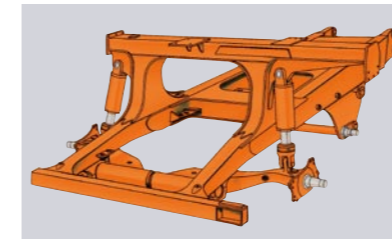

Full fabricated box section main rails with section height tapered from rear to front. Narrow at the rear to support the load and wider at the front allowing truck stability and excellent engine access for servicing. One piece top and bottom flanges that eliminate cross member tie in joints and provide a large exposed center area for access to major components. Large radii at frame junctions are blended and ground to minimize stress concentrations. Weld joints are oriented longitudinally to the principal flow of stress for greater durability and more strength. Frame utilizes 345 MPa yield high strength low alloy steel that is robotically welded to ensure consistently high quality welds.

Reinforced Body

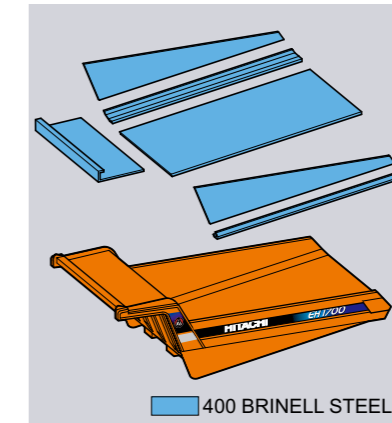

Built for quarry and mining applications, the EH1700 body uses a 18 mm floor plate and 8 mm side plates made of 400 BHN high-tensile steel. This provides high resistance to wear and impact. A low loading height and large target area allow easy, quick loading by a variety of loading tools.

Fully Hydraulic Brake

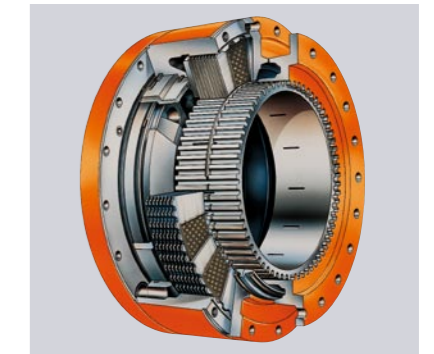

The fully hydraulic brakes feature high reliability, durability and serviceability. Optimum brake force yields maximum available braking under tough ground conditions for best control. Unique variable front to rear brake proportioning maximizes stop performance under slippery road conditions.

Ease of Operation



HI-TECH ROPS / FOPS Cab

The new Hi-TECH (Hitachi Technology) ROPS/FOPS Cab features a center integrated, “flat panel” style dashboard that positions the display and controls within close view of the road ahead. Appropriate positioning of the operator and generous sizing of the cab windows provide the operator with more ground area visibility. The cab uses double-wall construction and a 3-point rubber isolation-mount to absorb shocks and noise. The new high powered heater provides ample BTU's for all environments and working conditions. The new Hitachi controller, built by Hitachi and also used in excavators, will perform its function of processing input and output information with reliability during the most rigorous haul cycle.



Auto-Lubrication System (Optional)

A pump fed system automatically applies grease to lube points via plumbing. The lubricant is automatically delivered in time controlled and metered quantities to all connected lube points in the system. A choice between the Groeneveld or the Lincoln lubrication system is available.



Auto Lubricator (Groeneveld)

Operation and Error Indicator (Groeneveld)

Superior Suspension

The Hitachi trailing arm suspension system delivers excellent maneuverability, even at higher speeds. The trailing arm layout offers greater ease of servicing while improving truck performance compared to suspended king-pin designs. The pivot mounting of the trailing arm design allows only axial input to the strut and allows wheel movement in the vertical plane only.

Features:

- Lateral forces that act on the front wheels are minimized, resulting in reduced tire scuffing.
- Dynamic friction (side-wall force) within the strut is low due to the features of the trailing arm suspension design, allowing the use of a lighter strut engineered to a smaller diameter and longer stroke.
- The necessary frame bulk (horse-collar structure) needed to mount a suspended king-pin is non-existent.
- The elimination of the “horse-collar” member provides greater engine access.
- The NEOCON strut used with the trailing arm suspension, improves operator and component isolation, provides better hauler stability and predictable operational control.
- Locating the king-pin close to the wheel assembly and at a slight angle results in low “Dry Park Steering” effort.
- Development of the compressible media, NEOCON-E™ fluid (proprietary, silicone based, environmentally friendly) for use in the suspension strut with Helium gas, results in an improved energy absorption (isolation) system and an improved energy release (stability) system that responds favorably whether traveling empty or with payload in a wide range of ambient temperatures.

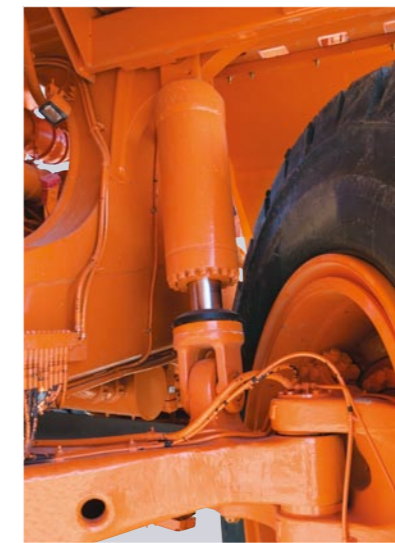
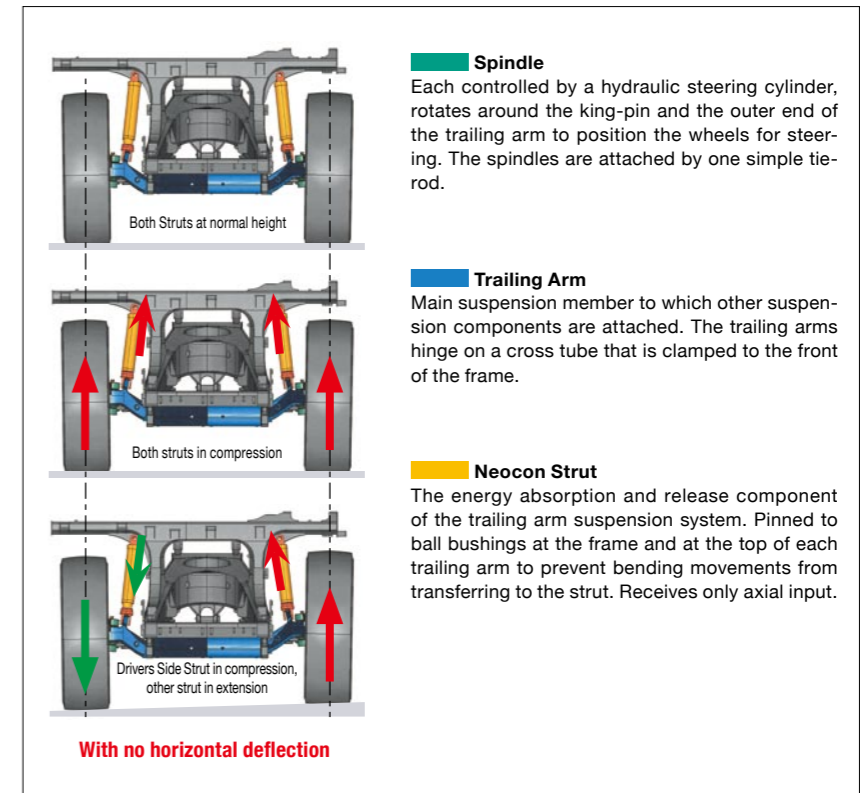

The trailing arm suspension design allows the front struts to be removed and installed without removing the front brakes or tires. This means fewer tools and less labor time are required, resulting in less downtime and higher productivity.

Trailing Arm Suspension (Front)

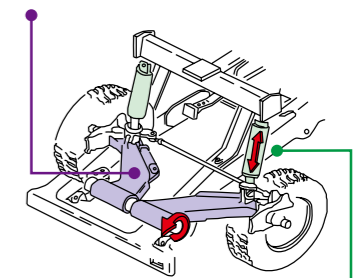

NEOCON Strut (Front/Rear)

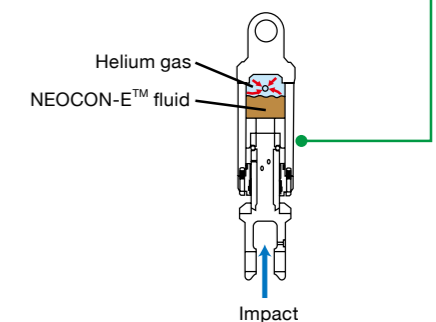

SPECIFICATIONS

ENGINE

Standard:

Model.....	MTU Detroit Diesel 16V Series 2000
Type.....	4 Cycle, V16, diesel injection
Emission Certification .	U.S. EPA Tier 2
Aspiration.....	Turbocharged / Aftercooled
Rated Power	
SAE J1995, gross ..	783 kW (1 050 HP) at 2 100 min ⁻¹ (rpm)
SAE J1349, net.....	710 kW (953 HP) at 2 100 min ⁻¹ (rpm)
ISO 9249, net.....	710 kW (953 HP) at 2 100 min ⁻¹ (rpm)
EEC 80/1269, net ..	710 kW (953 HP) at 2 100 min ⁻¹ (rpm)
Maximum Torque.....	4 461 N·m (454.9 kgf·m) at 1 350 min ⁻¹ (rpm)
Piston Displacement...	31.9 L
Bore and Stroke.....	130 x 150 mm
Torque Rise.....	25 %
Starting	Electric

Optional:

Model.....	MTU Detroit Diesel 16V Series 2000
Type.....	4 Cycle, V16, diesel injection
Emission Certification .	U.S. EPA Tier 2
Aspiration.....	Turbocharged / Aftercooled
Rated Power	
SAE J1995, gross ..	899 kW (1 205 HP) at 2 100 min ⁻¹ (rpm)
SAE J1349, net.....	826 kW (1 108 HP) at 2 100 min ⁻¹ (rpm)
ISO 9249, net.....	826 kW (1 108 HP) at 2 100 min ⁻¹ (rpm)
EEC 80/1269, net ..	826 kW (1 108 HP) at 2 100 min ⁻¹ (rpm)
Maximum Torque.....	5 296 N·m (540 kgf·m) at 1 500 min ⁻¹ (rpm)
Piston Displacement...	31.9 L
Bore and Stroke.....	130 x 150 mm
Torque Rise.....	30 %
Starting	Electric

TRANSMISSION

Standard:

Model.....	Allison H8610A
Design.....	Fully automatic, planetary type with integral lock-up converter
Mounting/Position.....	Remote from engine and rear axle for serviceability
Ranges	6 forward, 1 reverse
Control.....	Allison CEC2 electronics shift system with SEM (Shift Energy Management)

Maximum Speeds @Rated Engine Speed with standard 27.00R49(**)E4 tires

Gear	Ratio	km/h
1	4.24	9.6
2	2.32	17.5
3	1.69	24.1
4	1.31	31.1
5	1.00	40.7
6	0.73	55.7
R1	5.75	7.1

Optional:

Model.....	Allison H9610A
Design.....	Fully automatic, planetary type with integral lock-up converter
Mounting/Position.....	Remote from engine and rear axle for serviceability
Ranges	6 forward, 2 reverse
Control.....	Allison CEC2 electronics shift system with SEM (Shift Energy Management)

Maximum Speeds @Rated Engine Speed with standard 27.00R49(**)E4 tires

Gear	Ratio	km/h
1	4.24	9.6
2	3.05	13.3
3	2.32	17.5
4	1.67	24.4
5	1.00	40.7
6	0.72	56.5
R1	5.75	7.1
R2	4.13	9.9

DRIVE AXLE

Model Differential.....	2657
Axle Design.....	Full floating axle shafts using a model 2657 differential and single reduction planetaries at each wheel
Traction Control	An optional electronic feature that includes the Electronic Downhill Speed Control feature

Differential and Final Drive Ratios

Ratios	
Differential	3.15 : 1
Planetary	8.00 : 1
Total Reduction	25.2 : 1
Maximum Speeds	
with 27.00R49 tires	55.7 km/h

TIRES

Front	27.00 R49(**) E4 (Radial)
Rear.....	27.00 R49(**) E4 (Radial)
Rim Width	495 mm (19.5 in)
Optional tires and tread patterns may be available.	

Certain job conditions may require higher rated TKPH (TMPH) tires in order to maintain maximum production. Hitachi recommends evaluating the job conditions and consulting the tire manufacturer to make proper tire selection.

ELECTRICAL SYSTEM

Twenty-four volt starting, lighting and accessories system. One hundred ampere alternator with integral transistorized voltage regulator. Two 12 V heavy duty batteries capable of 1300 cold cranking amps, each, at -18 degree C (0 degree F). A Hitachi solid state reprogrammable controller controls and monitors hauler systems, provides output information to control gauges and lights and incorporates connections for diagnostic tools.

BODY CAPACITY

	m³
Struck (SAE)	39.5
Heap 3 : 1	54.1
Heap 2 : 1 (SAE)	60.4

Body capacity and payload subject to change based on customer specific material density, options and application.

WEIGHTS (Approximate)

Net machine weight stated below includes standard equipment. Net machine weight changes will directly affect the Nominal Payload.

Chassis with Hoist	52 672 kg
Body	15 465 kg
Net Machine Weight	68 137 kg
The Net Machine Weight specification includes operator and 100 % fuel.	

Nominal Payload	95.2 tonnes
Target GMOW	163 300 kg

The Nominal Payload specification is calculated using the Hitachi Loading Policy. Specific job site requirements may result in an adjustment to the Nominal Payload weight. Consult your Hitachi dealer for a truck configuration which will match your haulage application.

Major Options

The following list of options are examples which will change the Nominal Payload.

- Automatic Fire Suppression
- Body Liner
- Deck Mounted Muffler

Weight Distribution	Front	Rear
Empty	48 %	52 %
Loaded	33 %	67 %

STEERING SYSTEM

Closed-center, full-time hydrostatic steering system using two double-acting cylinders, pressure limit with unload piston pump and brake actuation/steering system reservoir. An accumulator provides supplementary steering in accordance with ISO 5010 (SAE J1511). The Operators steering wheel offers 35 degrees of tilt and 47.7 mm of telescopic travel.

Steering Angle	38 degrees
Turning Diameter: (SAE)	21.8 m
Steering Pump Output (at 2 100 min ⁻¹ (rpm))	158.1 L/min
System Pressure	19.0 MPa

HYDRAULIC SYSTEM

Two 2-stage, double-acting cylinders, with cushioning in retraction, inverted and outboard mounted. Separate Hoist/Brake Cooling reservoir and independent tandem gear pump. Control valve mounted on reservoir.

Body Raise Travel	60 degrees
Body Raise Time (at 2 100 min ⁻¹ (rpm))	12.8 s
Body Down Time (at idle)	15.5 s
Brake Cooling Pump Output (at 2 100 min ⁻¹ (rpm))	472 L/min
Hoist Pump Output (at 2 100 min ⁻¹ (rpm))	472 L/min
System Relief Pressure (Hoist)	20.3 MPa

BRAKE SYSTEM

Brake system complies with ISO 3450 (SAE J1473).

All-hydraulic actuated braking system providing precise braking control and quick system response. The Hitachi brake controller has a unique variable front to rear brake proportioning that maximizes the stopping performance under all road conditions.

Service

All-hydraulic actuated front disc brakes and rear oil-cooled wet disc.

WET DISC BRAKE

The Hitachi wet disc brake is engineered for long service life even in the most extreme environments. The wet disc brakes are located on the rear axle and provide service braking, secondary braking, and retarding. The brakes are a multi-plate design, and continuously oil-cooled. The sealed design protects against environmental contamination for prolonged service life. The wet disc brake is designed with automatic retraction to prevent drag. Separate pedals activate the service braking and retarding functions.

Front Axle - Dry Disc

Disc Diameter Each (2 discs/axle)	101.6 cm
Brake Surface Area Per Axle	13 899 cm ²
Lining Area Per Axle	4 129 cm ²
Brake Pressure (Max.)	19.0 MPa

Rear Axle - Oil-Cooled Wet Disc

Brake Surface Area Per Axle	79 277 cm ²
Brake Pressure (Max.)	13.8 MPa

Secondary

Two independent circuits within the service brake system provide back-up stopping capability. System is manually or automatically applied to stop machine within prescribed braking distance.

Parking

Dry disc mounted on differential input shaft. Controlled by a toggle switch on the dash. Automatically applied if brake hydraulic pressure is lost.

Size (Diameter)	686 mm
-----------------	--------

Retarder

Foot-operated valve controls all-hydraulic actuation of oil-cooled wet disc brakes on rear axle. System provides modulated pressure to rear brakes for constant speed control.

Continuous	1 051 kW	(1 410 HP)
Intermittent	1 820 kW	(2 440 HP)

Load/Dump Brake Apply

Through activation of a switch by the operator, a solenoid is energized, sending full brake pressure to apply the rear Wet Disc brakes. For use during the load and dump cycles.

HI-TECH ROPS / FOPS CAB

Hi-Tech ROPS / FOPS Cab

ROPS complies with ISO 3471 and SAE J1040-May 94. FOPS complies with ISO 3449. Double wall construction of 11 gauge inner and outer steel panels, lends itself to a more structurally sound cab. Multiple layered floor mats act to absorb sound and control interior temperature. A properly maintained cab from Hitachi, tested with doors and windows closed per work cycle procedures in ISO 6394: 1998 (dBA), results in an operator sound exposure Leq (Equivalent Sound Level) of 81 dB(A). A three-point rubber isolation-mount arrangement to the deck surface minimizes vibration to the operator compartment.

Excellent Serviceability

A removable front panel allows easy access to service brake valves, retarder valve and heater assembly. A removable cover located behind the operators seat provides easy access to the Transmission Controller (TCU), Central Controller (CCU) and all electrical junction points.

Comfort and Ease of Operation

A flat panel style dashboard positions controls within easy reach and visual contact. A full complement of easy-to-read gauges, automobile type monitor with warning system, a spacious environment, multiple position adjustable seat, tilt/telescopic steering wheel, filtered cab ventilation and door locks all contribute to operator convenience, control and comfort.

SPECIFICATIONS

SUSPENSION

Front and Rear Suspension

The trailing arm suspension system features independent trailing arms for each front wheel with NEOCON struts, containing energy absorbing gas and compressible NEOCON-E™ fluid, mounted between the king pins and the frame. This arrangement allows a wider front track that provides a better ride, improved stability and a reduced turning circle. The rear axle housing has an A-frame mounting. The rear NEOCON struts are mounted in a more vertical position which allows a more pure axial loading and reduces the tractive and braking forces transmitted through the parallel links to the frame.

NEOCON struts outperform competitive strut designs by improving isolation, stability, and control. Improved isolation means reduced impact loading on the structural members of the machine and greater operator comfort, resulting in longer equipment life and increased productivity. Improved stability means more consistent dynamic response of the machine to fluctuating load energy, resulting in predictable machine performance. Improved control means better machine maneuverability.

The Hitachi frame and trailing arm suspension system are designed to work in unison to provide maximum structural integrity and operator comfort. The fabricated rectangular frame rail construction provides superior resistance to bending and torsional loads while eliminating unnecessary weight. The unique independent trailing arm suspension absorbs haul road input, minimizing suspension-induced frame twisting while providing independent tire action. NEOCON ride struts are mounted with spherical bushings, eliminating extreme sidewall forces by ensuring a purely axial input to the ride strut. The wide track stance of the trailing arm suspension system and the long wheel base assure a more stable, comfortable ride.

BODY

The body has been made to the flat floor, flat tail chute design. The rear hinge has been designed to allow the hinge pin to float when the body is in the fully lowered position. The weight of the body and payload is distributed across rubber body pads that are evenly spread across the length of the body rail-box that rests on the truck frame.

Plate Thickness (Standard Body):

	mm	(in)
Floor	18	(0.69)
Front	8	(0.31)
Sides	8	(0.31)
Canopy	5	(0.188)
Valley	11	(0.44)

Options for Standard Body:

Body Liners (Medium Duty)		
Floor & Valley	10	(0.38)
Sides & Front	6	(0.25)
End Protection	6	(0.25)
Body Liners (Heavy Duty)		
Floor & Valley	16	(0.63)
Sides & Front	8	(0.31)
End Protection	6	(0.25)
Partial Liner (Heavy Duty)		
Floor & Valley	16	(0.63)
End Protection	6	(0.25)
Rock Cap		
Top of the Body Side Plate	10	(0.38)

The horizontal stiffener design of the Hitachi body minimizes stress concentrations in any one area. Load shocks are dissipated over the entire body length.

The closely spaced floor stiffeners provide additional protection by minimizing distance between unsupported areas.



SERVICE CAPACITIES

	L
Crankcase (includes filters)	118.3
Transmission, Cooler and Lines	99.0
Cooling System	497
Fuel Tank	1 136
Hydraulics	
Hoist Tank and System	448
Steering Tank and System	170
Drive Axle (2 wheels and differential)	322
Windshield Washer Fluid	5.7

STANDARD EQUIPMENT

GENERAL

All-hydraulic braking	Fuel tank level gauge
Battery disconnect switch	Fuel/Water Separator
Body down cushioning	Guard rails
Body down indicator	HID headlamps and LED tail-lights
Body prop cable	Hoist interlock
Body up speed restriction w/light	Hoist tank sight glass
Brake accumulators	ISO decals
Canopy spill guard	Load/dump brake
Continuous body heating	Mirrors, left and right, hand adjustable
Cooling system surge tank	Mud flaps
Driveline guard, front	NEOCON-E suspension struts
Dual cab access ladders	Parking brake - dry disc
Electric horns	Parking brake interlock
Electric start	Reverse alarm and light
Electronic air conditioning system, 30 500 BTU/hr	Rear view camera system
Electronic heater system, 40 000 BTU/hr	Rock ejector bars
Electronic hoist	Steering accumulator
Engine access ladders	Steering tank sight glass
Engine belt protection	Tires 27.00R49
Engine service lights	Tow points, front
Fan guard	Transmission guard
Front view mirror	Transmission sight gauge
Fenders	Wet disc brake wear indicators
Fixed steering stops	24 volt to 12 volt converter
Front brake cut-off, switchable	

CAB

Air Conditioning	ISO driver envelope
Air filtration/replaceable element	Instrumentation cluster, electronic
Antenna and speakers	Quick connect hydraulic test ports
Ashtray	Rubber floor mat
Cab interior light	Safety glass
Camera monitor	Seat belts, retractable (operator and trainer)
Cigar lighter, 24 volt	Seat, air-ride, 3" lap belt*
Door locks	Sun visor
Driver and trainer window activation mechanical	Tilt/telescoping steering wheel
Foot rest, left	Tinted glass, all windows
Fuses	Trainers seat
Heater and defroster	12 volt accessory connection
Integral ROPS/FOPS cab	Windshield washer
Integrated engine diagnostics connector	Windshield wiper, intermittent
Integrated transmission diagnostics connector	

* Features

Parking brake alarm: Audible when parking brake is not applied and operator is not seated
Seat belt alarm: Audible and visible when truck is running and seat belt is not buckled

EQUIPMENT / DIMENSIONS

ELECTRONIC DISPLAY (Hitachi Monitoring Information)

Lights with ISO symbols	Filter restrictions
Active Traction Control (optional)	High beam
Battery charge	Parking brake
Body up	Payload red (optional)
Brake system oil pressure	Payload yellow (optional)
Central warning (stop)	Retarder temperature
Central warning (yellow caution)	Seat belt disconnected
Electronic downhill speed control (optional)	Steering oil pressure
Engine coolant level	Transmission oil pressure
Engine oil pressure	Transmission oil temperature
	Turn signal/ hazard

LCD (Liquid Crystal Display)

Adjustable units of measure	Park brake applied
Brake oil pressure	Service intervals
Brake oil temperature	Steering oil pressure
Date and time	Steering oil temperature
Distance travelled	System diagnostics
Engine coolant temperature	Transmission oil pressure
Engine oil pressure	Transmission oil temperature
Engine RPM	Transmission range selection
Hourmeter	Travel speed
Load Count	Voltmeter
Odometer	

GAUGES

Engine coolant temperature	Speedometer
Fuel gauge	Tachometer

MACHINE LIGHTS

Amber turn signals and four-way flashers	Clearance light - rear (2)
Back-up light (1)	Dual combination stop and taillights (2)
Clearance light - front (2)	Headlights (4)

OPTIONAL EQUIPMENT

CAB

Active Traction Control (ATC) w/ Electronic Downhill Speed Control (EDSC)	Hill hold brake
AM-FM radio w/ CD and auxiliary input	Indicator light, payload red
Battery equalizer	Indicator light, payload yellow
Circuit breakers, 12 and 24 volt	LCD display, payload meter
Driver and trainer window activation, electric	Satellite radio
HAULTRONICS III load monitoring system	Semi-active operators seat, w/heat, w/lumber and 3 point seat belts*

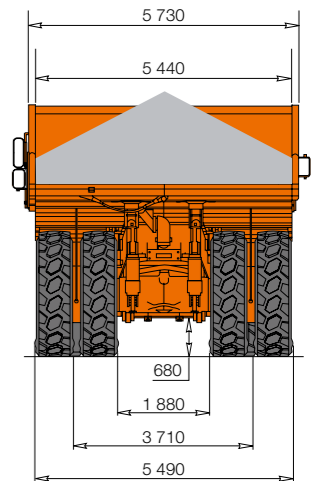
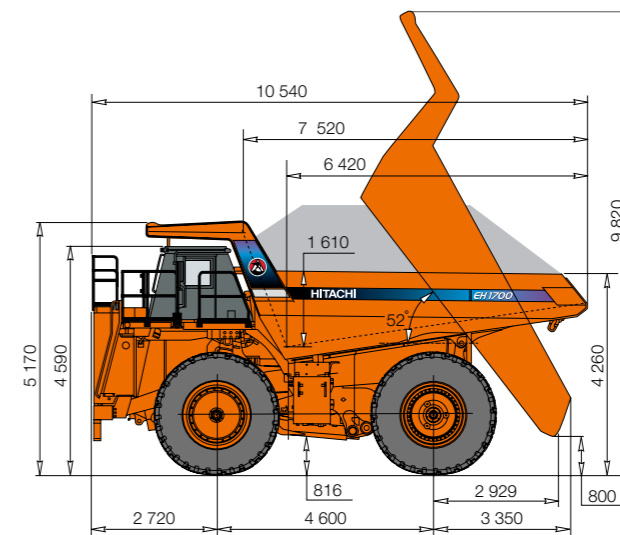
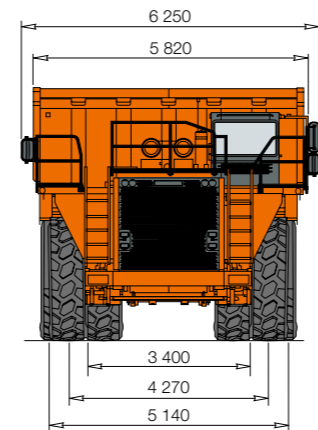

CHASSIS

Backup lights, additional to taillight group	High output powertrain, 899 kW MTU 16V-2000 engine and Allison H9610A transmission
Backup lights, auxiliary halogen deck mounted	Hill hold brake
Backup lights, auxiliary HID deck mounted	LHS arm guard
Body liners (400BHN) plates, medium, heavy duty or partial	Lube system, centralized
Body sizes 64 m ³ , 68 m ³ , 80 m ³ Custom sizes upon request	Lube system, Groeneveld
Cold weather package Mild cold weather package (0 deg C to -20 deg C) Extreme cold weather package (-20 deg C to -35 deg C)	Lube system, Lincoln
Electrically heated mirrors	Muffler, deck mounted
Engine cooling fan clutch	Rear driveline guard
Fire protection, deck mounted hand-held	Rim (model choices)
Fire protection, manual Ansul system	Rock cap
Fluid draining kit	Service center with fast fuel, RHS and LHS
Fluid sampling ports	Side extensions
Fog lights	Side view camera (RHS)
Ground level engine shutdown	Side mudguards, mounted to cab deck
	Spare rim
	Spill guard 10" installed to canopy
	Synthetic transmission fluid
	Tires (type and rating)
	Tool kit
	Unit sound suppression

MISCELLANEOUS

Extra operators manual	Service manuals
Extra parts manual -choice of hardcopy or CD	-choice of hardcopy or CD

OPTIONAL EQUIPMENT WEIGHT

	kg
LHS arm guard	60
Body liners (400BHN) plates, medium	3 813
Body liners (400BHN) plates, heavy duty	5 862
Body liners (400BHN) plates, partial	4 915
Lube system, Groeneveld	150
Lube system, Lincoln	100
Rock Cap	272
Spill guard	143

Standard and optional equipment may vary from country to country. Special options provided on request. All specifications are subject to change without notice.

unit : mm

PERFORMANCE DATA

**Performance Chart for EH1700 with Standard
1 050 HP Engine and Standard H8610A Transmission**

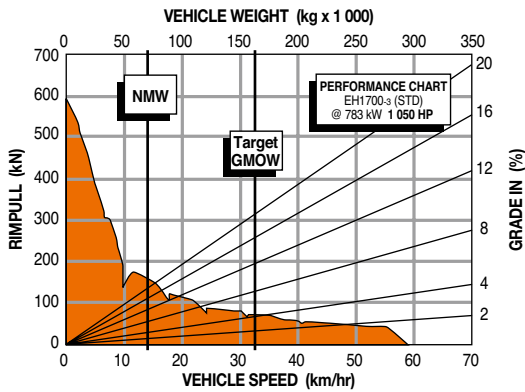

**Performance Chart for EH1700 with Optional
1 205 HP Engine and Optional H9610A Transmission**

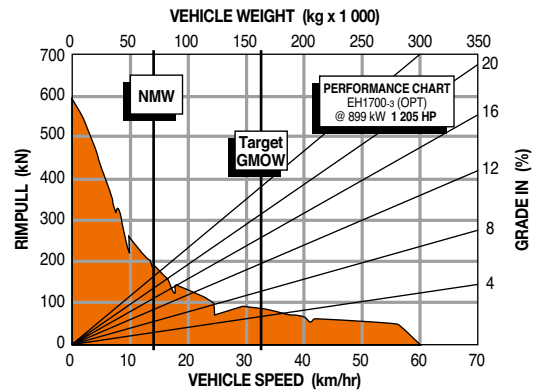

**Retarder Chart for EH1700 with Standard
1 050 HP Engine and Standard H8610A Transmission**

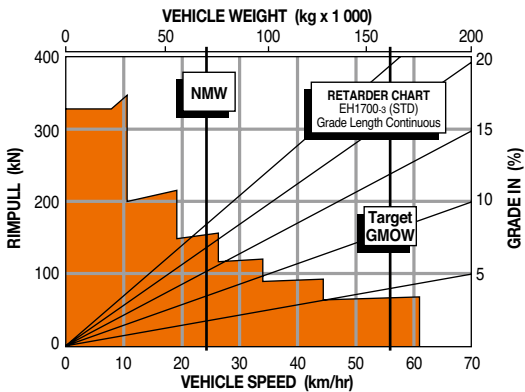

**Retarder Chart for EH1700 with Optional
1 205 HP Engine and Optional H9610A Transmission**

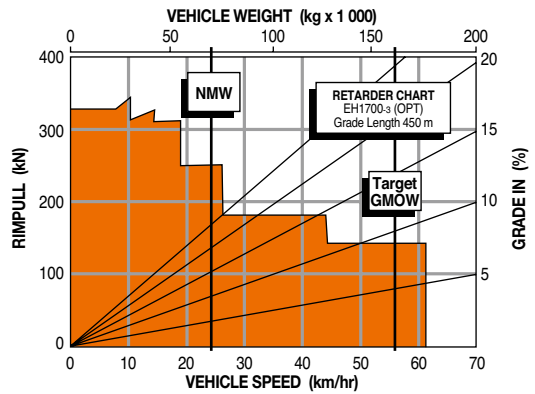
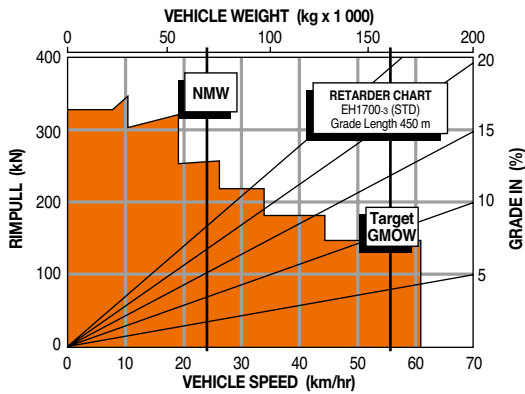
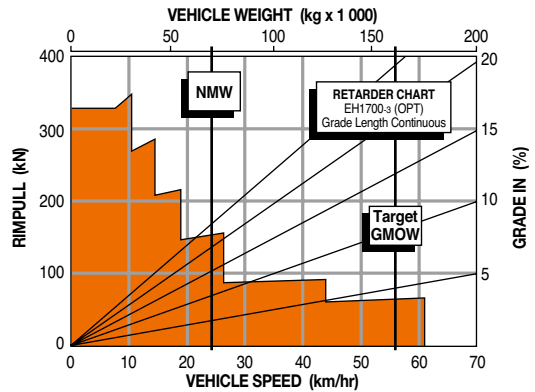

NOTES:

Diagonal lines represent total resistance (Grade % plus rolling resistance %).

Charts based on 0 % rolling resistance, standard power of each engine, standard tires and gearing unless otherwise stated.

1. Find the total resistance on diagonal lines on right-hand border of rimpull or retarder chart.
2. Follow the diagonal line downward and intersect the NMW or GMOW weight line.
3. From intersection, read horizontally right or left to intersect the rimpull or retarder curve.
4. Read down for machine speed.

These specifications are subject to change without notice.

Illustrations and photos show the standard models, and may or may not include optional equipment, accessories, and all standard equipment with some differences in color and features. Before use, read and understand the Operator's Manual for proper operation.