

Dimensions

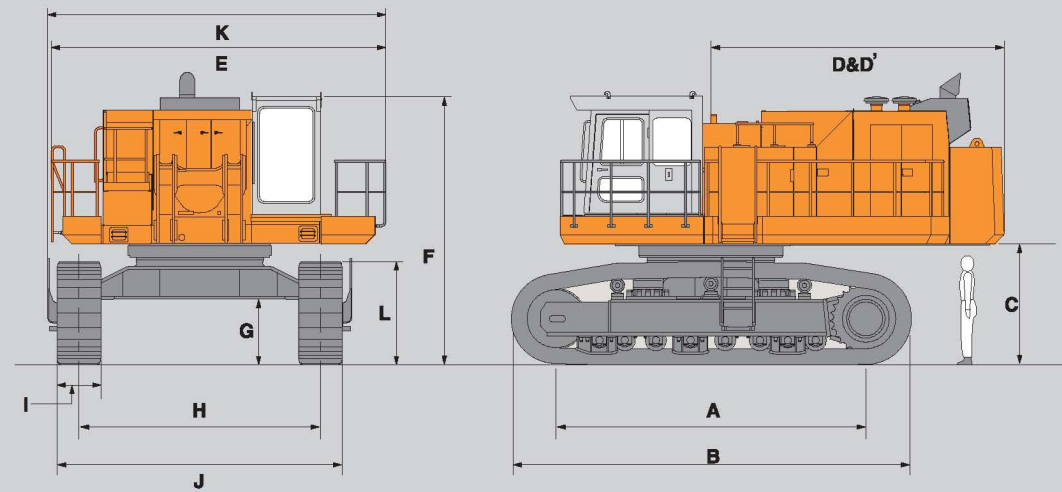

A	Distance between tumblers	5 000
B	Undercarriage length	6 410
C	Counterweight clearance	1 790
D	Rear-end swing radius	4 850
D'	Rear-end length	4 740
E	Overall width of upper structure	5 380
F	Overall height of cab :Low cab	4 320
	:High cab	5 410

G	Min. ground clearance	990
H	Track gauge	3 900
I	Track shoe width	710 / 900
J	Undercarriage width	4 610 / 4 800
K	Overall width	5 430
L	Track height	1 570

All dimensions are in mm.

TELCON OFFICES

PLACE	PHONE	FAX	PLACE	PHONE	FAX
AHMEDABAD	079-66096600 / 77	66096660	LUCKNOW	0522-65691512 / 13 / 14	2305775
AURANGABAD	0240-2352289 / 90	2352188	MADURAI	0452-6541001, 6541002	4210250
BANGALORE	080-22210239, 22243788	22293030	MUMBAI	022-26504400	40400450
BHUBANESHWAR	0674-2582017 / 23	2582112	NAGPUR	0712-646020 / 21 to 35	235494
CHANDIGARH	0172-5065472 / 3	5065473	NELLORE	0861-2317697 / 98	2317696
CHENNAI	044-22321501 / 2	22321501	NEW DELHI	011-26817291 / 92	26811820
COCHIN	0484-2336375	2330712	PATNA	0612-6457382	2323158
DURGAPUR	0343-6455649	9233310710	PUNE	020-65704826 / 28	25234027
GOA	0832-2730008	2730008, 2725260	RAIPUR	0771-4013499	2413396
GUWAHATI	0361-2411147, 2411263	2419170	RAJKOT	0281-6595314 / 15 / 16	6595317
HUBLI	0836-6453481 / 82	6453481	SALEM	0427-2225001, 2225009	2225003
HYDERABAD	040-27538772/3/4/5	27538771	UDAIPUR	0294-6535558 / 9	2425313
INDORE	0731-4064420, 4064791	4065768	VIZAG	0891-2562114, 2525332	2560389
JABALPUR	0761-6455748	4081922	MANUFACTURING FACILITY		
JAIPUR	0141-6535558 / 6545559	2812398	JAMSHEDPUR PLANT	0657-6691305 / 06	2268882
JAMSHEDPUR	0657-6572397	2386242	DHARWAD PLANT	0836-6623501 / 08	2486907
KOLHAPUR	0230-2468013	2468012	KHARAGPUR PLANT	03222-218340 / 646020 / 2644014	
KOLKATA	033-26690723 to 26	26690717			

THCM / HEX / EX1200 / ZOP / Nov / 2012 / Qty 200 Nos



TATA HITACHI

Reliable solutions

THE TECHNO GIANT

EX 1200V

Operating Weight

Backhoe : 111 000 kg
Shovel : 111 000 kg

Bucket Capacity

Backhoe : 3.0 - 7.1 m³
Shovel : 5.9 - 6.5 m³

Rated Engine Power : 760 HP @ 1650 rpm



TATA HITACHI

Reliable solutions

Tata Hitachi Construction Machinery Company Limited

Registered Office: Jubilee Building 45 Museum Road Bangalore 560 025 India
Telephone: +91 80 66953301 02 03 04 05 Fax: +91 80 66953309 25325792

Toll Free : 1800 3456 500

Computer - Aided
Engine - Pump
Control System

Strong Front
Attachment and
Undercarriage

Unmatched
Productivity and
Reliability

Easy Maintenance
and Reduced Total
Lifetime Cost

Data Logging
Unit

The specifications are subject to change without prior notice. Please contact our nearest office for latest specifications.
Accessories shown here are not part of the standard equipment. Performance of the machine may vary with site and operating conditions encountered.



Transportation

Overall

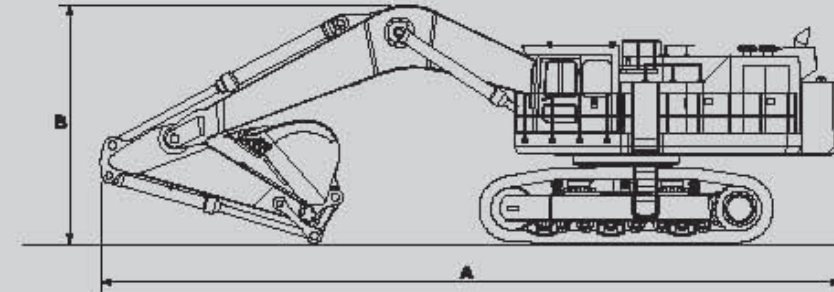

	A	B	Width
EX 1200-V	16 170 mm	5 720 mm	5 470 mm
EX 1200-V BE-beam	14 620 mm	6 400 mm	5 470 mm

Lifting Capacities

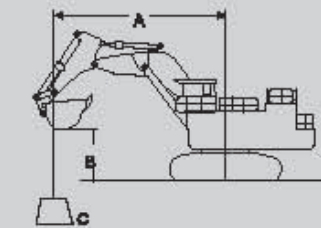

A : Load radius
B : Load point height
C : Lifting capacity

: Rating over-side or 360 degrees : Rating over-front Unit: 1,000 kg

Conditions	Load point height	Load radius										At max. reach				
		3 m		4 m		6 m		8 m		10 m		12 m		meter		
EX1200-V BE-Boom 7.55 m BE-Arm 3.4 m Bucket-6.5° Shoes 710 mm	8 m									14.6	14.6			16.19	16.19	12.6
	6 m									15.5	15.5			16.48	16.48	13.1
	4 m							22.4	22.4	17.2	17.4	11.6	12.9	15.81	15.81	13.2
	2 m							24.5	24.5	17.2	19.2	11.6	14.1	16.56	16.56	13.0
	0 (Ground)							23.7	26.4	16.1	19.5	11.1	15.7	16.47	16.47	12.4
	-2 m							23.7	28.9	14.1	21.5	11.1	16.1	17.27	17.27	11.2
	-4 m							22.4	28.3	15.2	20.7	10.7	13.7	17.62	17.62	
	-6 m							22.4	31.0	15.2	21.7	10.7	14.9	18.48	18.48	

Conditions	Load point height	Load radius										At max. reach				
		3 m		4 m		6 m		8 m		10 m		12 m		meter		
EX1200-V Boom 9.1 m Arm 3.4 m Bucket-5.0° Shoes 710 mm	8 m													9.88	9.88	14.1
	6 m									15.2	15.2			9.64	9.73	14.6
	4 m									16.8	16.8			9.54	9.77	14.8
	2 m									17.2	17.2			8.01	9.21	14.8
	0 (Ground)									17.5	19.0			8.01	10.1	14.8
	-2 m									16.3	19.1			7.97	9.78	14.1
	-4 m									16.3	21.1			7.97	10.7	14.1
	-6 m									15.5	20.3			8.44	11.7	14.1

With heavy lifting system

Notes
1. Ratings are based on SAE J1087.
2. Lifting capacity of the EX Series does not exceed 75% of tipping load with the machine on firm, level ground or 80% full hydraulic capacity.
3. The load point is a hook (not standard equipment) fixed on the back of the bucket.
4. *Indicates load limited by hydraulic capacity.

Transportation

Backhoe Attachments

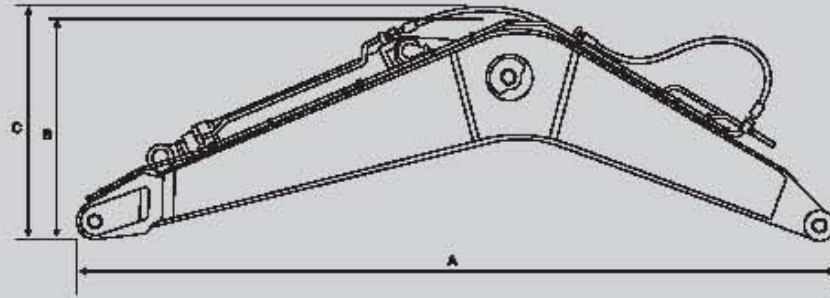

	Boom length	A	B	C	Width	Weight
EX 1200-V	9.1 m	9 500 mm	2 810 mm	3 100 mm	1 460 mm	9 660 kg
EX 1200-V BE-beam	7.55 m	7 960 mm	3 150 mm	3 400 mm	1 460 mm	9 080 kg

Boom cylinders

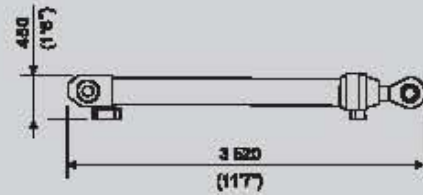

Weight: 1 170 kg x 2

Arm

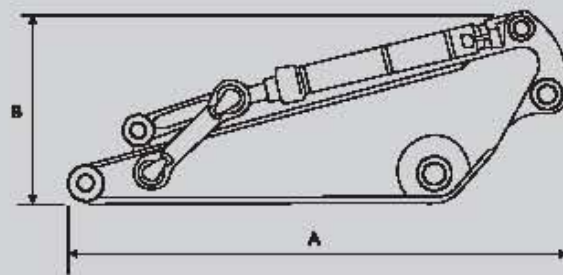

	Arm length	A	B	Width	Weight
EX 1200-V	3.4 m	4 830 mm	1 850 mm	960 mm	5 970 kg
	4.5 m	5 975 mm	1 700 mm	960 mm	6 300 kg
	5.8 m	7 200 mm	1 750 mm	985 mm	5 930 kg
EX 1200-V BE-beam	3.4 m	4 880 mm	1 850 mm	960 mm	6 100 kg

Bucket

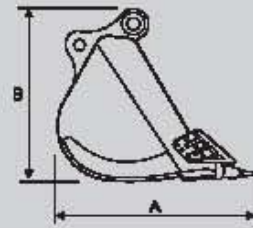

Capacity PCSA heaped	A	B	Width	Weight	Type
3.0 m ³	1 890 mm	2 310 mm	1 800 mm	3 100 kg	●
3.4 m ³	1 890 mm	2 310 mm	1 940 mm	3 250 kg	○
3.5 m ³	2 300 mm	2 480 mm	1 460 mm	4 300 kg	●
3.6 m ³	2 280 mm	2 240 mm	1 600 mm	4 030 kg	○
4.0 m ³	2 280 mm	2 480 mm	1 720 mm	4 160 kg	○
4.5 m ³	2 280 mm	2 480 mm	1 900 mm	4 300 kg	○
4.5 m ³	2 300 mm	2 480 mm	1 810 mm	4 650 kg	●
5.0 m ³	2 460 mm	2 250 mm	2 100 mm	4 490 kg	○
5.0 m ³	2 560 mm	2 280 mm	1 960 mm	5 460 kg	●
5.6 m ³	2 460 mm	2 250 mm	2 240 mm	4 720 kg	○
5.6 m ³	2 630 mm	2 260 mm	2 240 mm	6 510 kg	●
6.0 m ³	2 710 mm	2 240 mm	2 280 mm	6 170 kg	○
6.5 m ³	2 710 mm	2 240 mm	2 310 mm	6 350 kg	○
7.1 m ³	2 940 mm	2 240 mm	2 500 mm	6 680 kg	○

● : Neck bucket ○ : General purpose bucket

New Giant

OFFERS TRUE VALUE

With the huge TATA Hitachi EX 1200 - V you'll find all the essentials of a truly outstanding machine. Rest assured that like all TATA Hitachi equipment, the EX1200-V has been designed for safety, productivity, durability and comfort. TATA Hitachi has blended the latest technology with tough performance to create what it calls the "New Giant" that is ready to take on the excavating needs of today and tomorrow. Telcon makes this possible for you with the amazing power of this Giant.

With Telcon, you can handle Anything. Anywhere. Anytime.

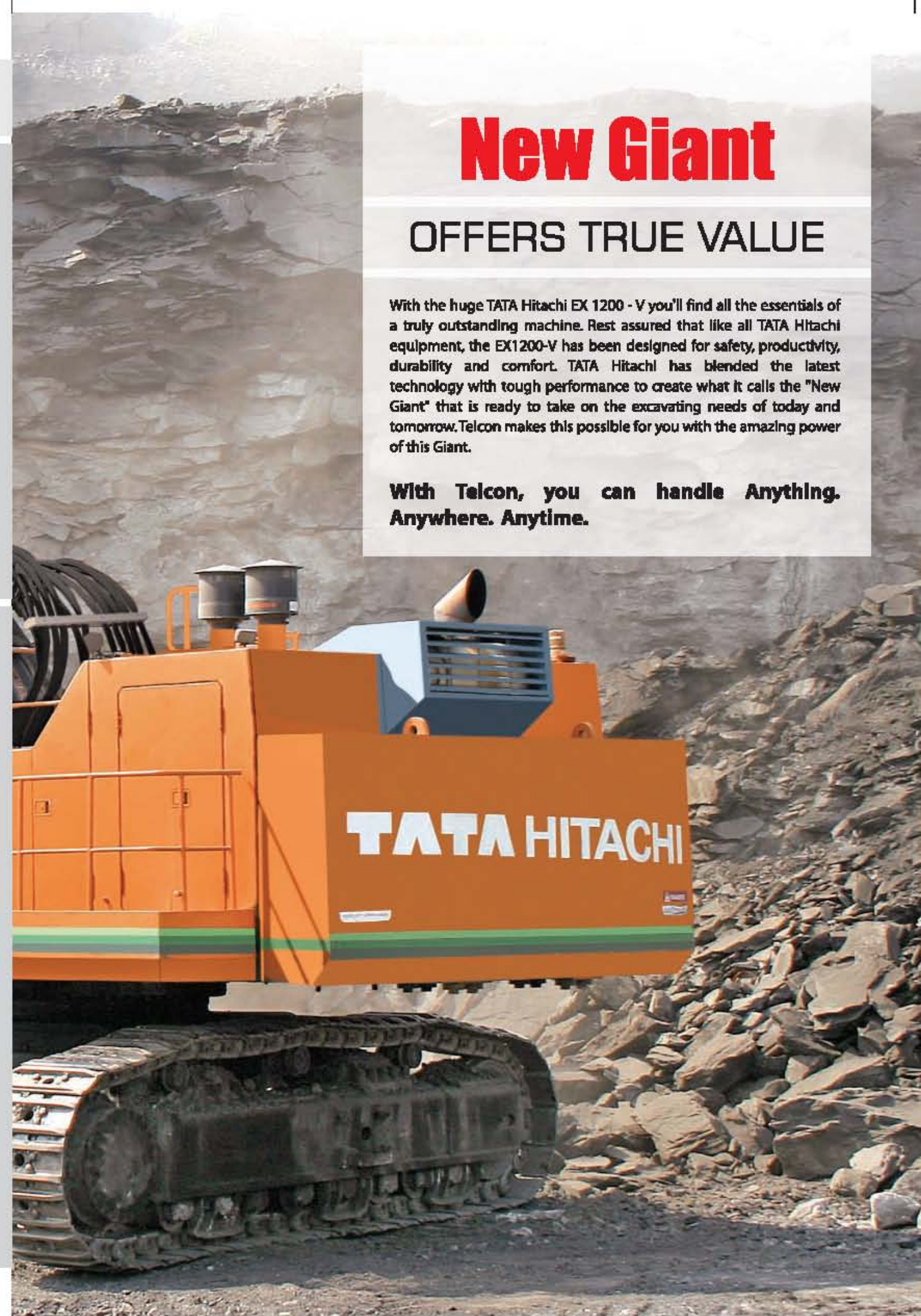

Higher Production

With the new Giant you can experience a 30% increase in production when compared to EX1100-3 using BE front and S/P mode.

More Powerful Engine

The source of high production. The EX1200-V is equipped with a powerful large-displacement engine. An intercooler is used to provide optimal fuel efficiency, helping to keep total running costs down.

Larger Bucket

Provides high work capacity. The large capacity bucket offers an increased excavating power-to-bucket-width ratio. The result is increased work efficiency for higher production.

More Powerful Excavation

Increased power for excavating. The powerful engine is combined with a highly efficient hydraulic system to offer the excavating power for even the toughest sites.

Maximum Excavating Force

- 9.1m boom / 3.4m arm with General purpose bucket. 46 600kgf
- 7.55m BE-Boom / 3.4m BE-arm with General purpose bucket. 56 100kgf
- 7.55m BE-Boom / 3.4m BE-arm with Rock bucket. 56 100kgf

Combined Front Operations

Fast and efficient operation. The popular Optimum Hydraulic System (OHS) is used along with the newly developed arm regenerative and boom regenerative mechanism for smooth and efficient front operations.

E/P Control

Provides a balance between economical operation and power. Speed sensing control is used to efficiently control engine output. This system incorporates a microcomputer to regulate engine and hydraulic pump output to the level of work being performed.

- S/P mode increases productivity - Choose the S/P mode to boost power during strenuous operation.
- E mode reduces fuel consumption - This mode lowers fuel consumption during light-duty operations.

Auto Idle and Quick Idle

With the help of auto idle and quick idle you can reduce fuel consumption even more.



Auto Level Crowd Mechanism
Contributes to increased productive



E/P Control



Quick Idle Switch

Transportation

Undercarriage

Side frame

Weight: 14 600 kg x 2

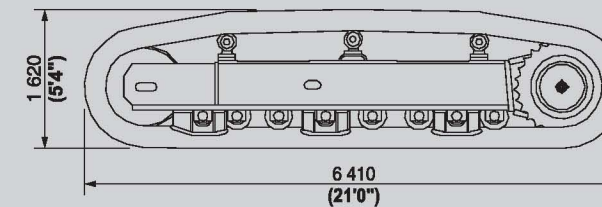

Width: 710 (2'4")

Loading Shovel Attachments

Bucket

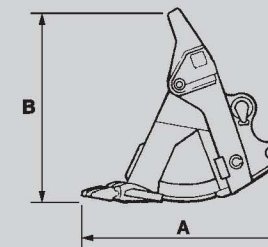

Bucket capacity	A mm	B mm	Max Width mm	Weight kg
5.9 m ³	2 770	2 480	2 690	9 780 kg
6.5 m ³	2 770	2 680	2 890	9 200 kg

Traction device cover

Weight: 24 kg x 2

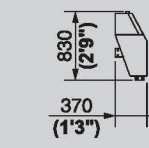

Width: 330 (1'1")

Steps

Weight: 18 kg x 2

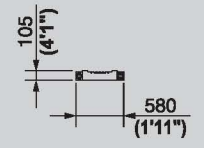

Width: 125 (2'9")

Ladder

Weight: 20 kg x 2

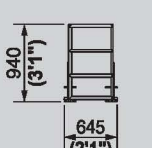

Width: 300 (11'9")

Boom & arm assembly

Weight: 15 200 kg

Width: 1 620 (5'4")

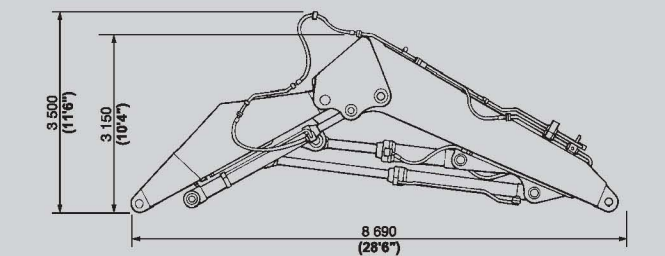

Boom Cylinders

Weight: 1 170 kg

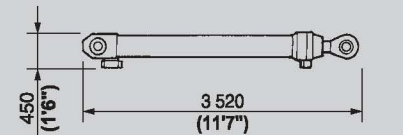

Overall

Loading Shovel

Weight: 111 000 kg

Width: 5 470 (17'11")

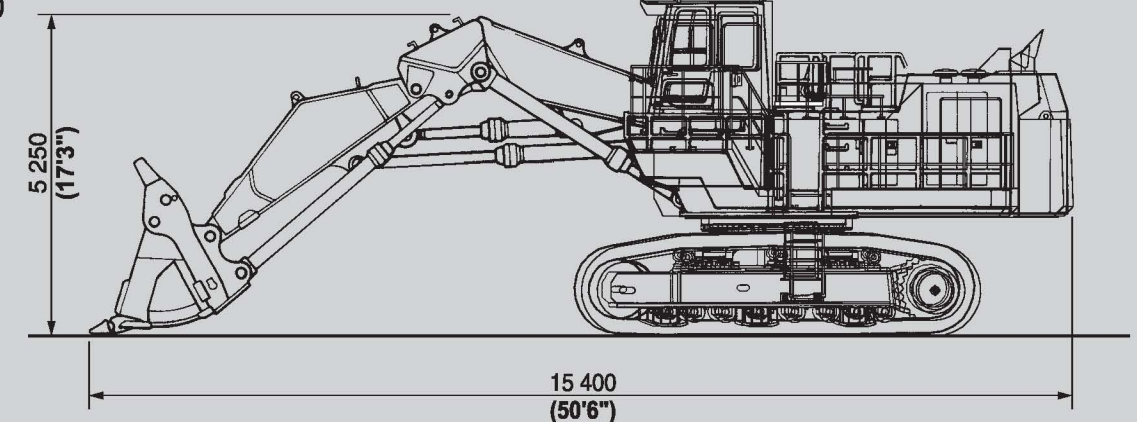

Transportation

- Easily assembled owing to local assembling system, requiring no welding.
- Overall width below 3 500 mm (11'6") during transportation

Superstructure

Upperstructure

Weight: 33 900 kg

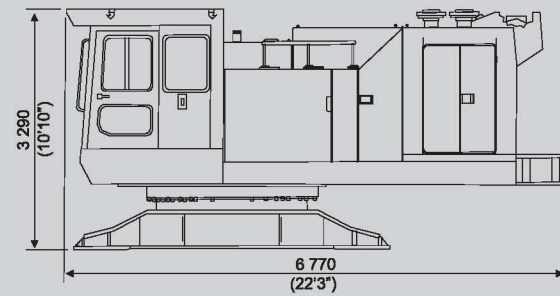

Width: 3 500 (11'6")

Side step

Weight: 21 kg

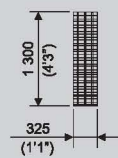

Width: 110 (4")

Side walk for Backhoe

Weight: 217 kg

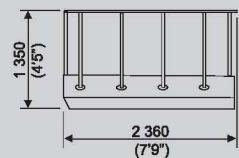

Width: 1 020 (3'4")

Step for loading shovel

Weight: 145 kg

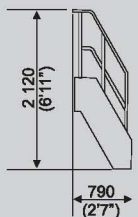

Width: 1 050 (3'5")

Side walk

Weight: 253 kg

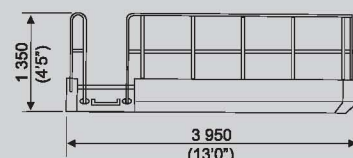

Width: 796 (2'7")

Handrail

Weight: 264 kg

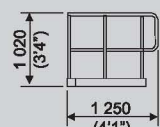

Width: 680 (2'3")

Handrail

Weight: 46 kg

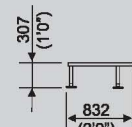

Width: 50 (0'2")

Counterweight

Weight: 17 500 kg

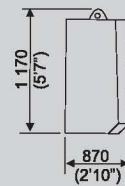

Width: 3 450 (11'4")

Side walk for Loading shovel

Weight: 180 kg

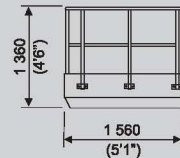

Width: 1 050 (3'5")

High cab kit for Loading shovel (Optional equipment for Backhoe)

Weight: 590 kg

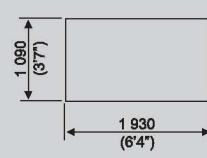

Width: 1 100 (3'7")

Side walk

Weight: 181 kg

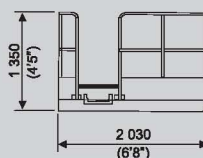

Width: 835 (2'9")

Side walk

Weight: 18 kg

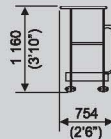

Width: 192 (7.6")

Radiator cover

Weight: 93 kg

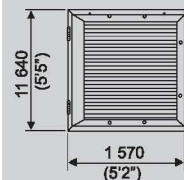

Width: 100 (3.9")

Oil cooler cover

Weight: 85 kg

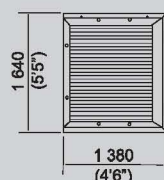

Width: 100 (3.9")

Higher Production



Heavy Lifting Function

Increases boom lift performance by 10%

A touch of the button gives the added power for breaking up rock or working under harsh conditions.

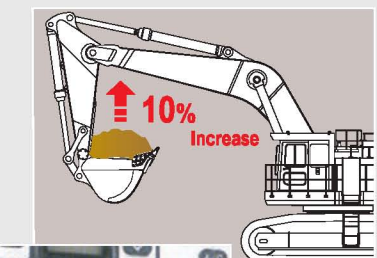

Environmental Friendly

Cleaner Operating Engine

Steps have been taken to reduce harmful exhaust gas emissions. This engine is equipped with an electronic governor and meets strict EPA* standards. (*Environmental Protection Agency of the United States of America)

Strong Front Arm

Rock Bucket

Designed for harsh work conditions. Reinforced bucket is designed specially for withstanding the impact encountered when handling crushed rock.

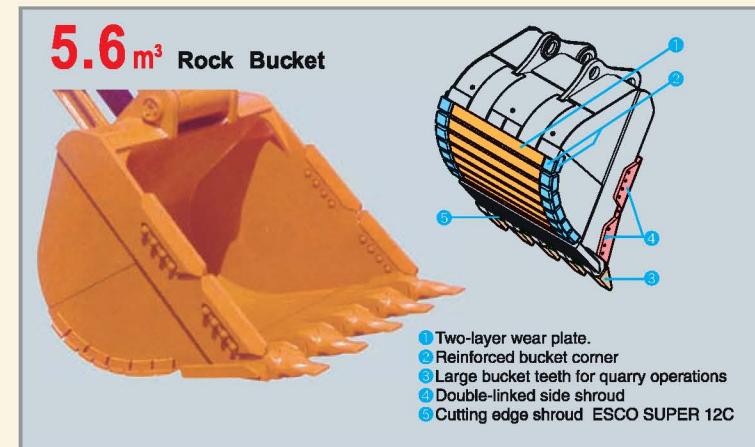

Under Plate Protection

A special plate and square bars are used to help prevent arm denting. The damage prevention plate, fitted with reinforcing square bars, is installed as standard on the arm. This protects the arm bottom from damage from loaded rocks.



Large Displacement Engine with Low Operating RPM

Provides a reliable power source. This large-displacement engine with power to spare will provide a long service life.

Boom & Arm

Designed for durability. A box-section structure has been adopted on the front attachment for its large cross-sectional area. In addition, bulkheads arranged inside the front attachment increases rigidity to resist torsion, further strengthening the structure. The enhanced durability will be specially welcome for extended operation at tough work sites such as mines.



Reinforced Pin Section

To provide a long service life to the arm end.

- Replaceable wear-resistant plate at the arm tip boss.
- Arm tip pin converted from fixed type to floating pin, extending service life.

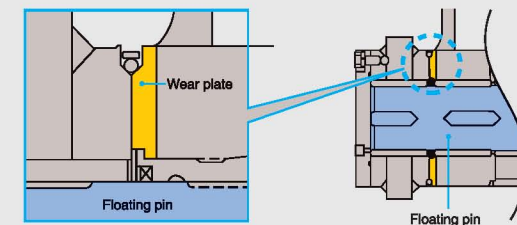

Independently Mounted Oil Cooler

Reduced heat helps increase hydraulic component durability.

The oil cooler and the radiator have been mounted in separate locations to reduce heat build up and increase cooling efficiency. Lower hydraulic oil temperature helps to increase the durability of hydraulic components.



Specifications

Boom and arm are all-welded, low-stress, full-box section design. Bucket of all-welded high-strength steel structure, side clearance adjust mechanism is provided on the bucket joint brackets.

- Two-points support-type boom cylinder pin linkage.
- Double lip pin seals (in all portions) plus O-ring with protector ring at arm top and link A.

- Flexible pin at the arm tip.
- Wear-resistant plate at the arm-tip boss.

BE (Bulk Excavation) front
BE Front: The EX1200-V BE front is designed and manufactured as a production-oriented machine. Its features include a short arm and boom, large-capacity bucket, large-digging force and superb digging / loading capability.

Working Ranges

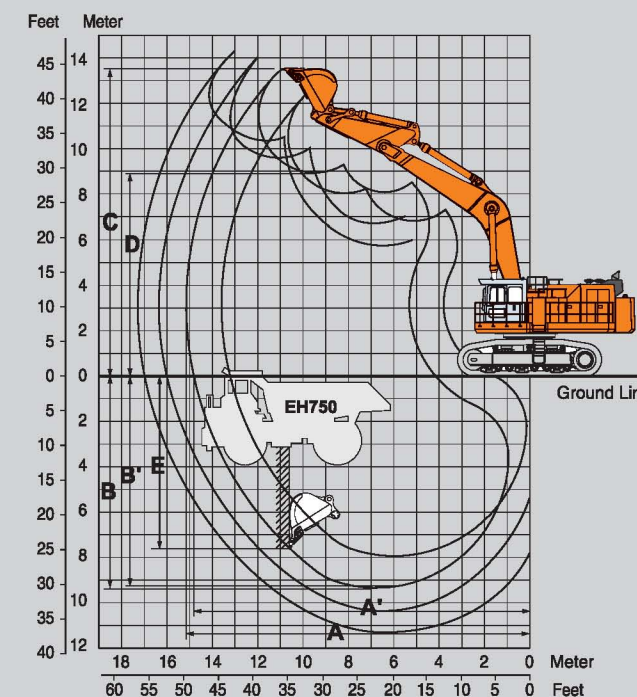

	Boom length	7.55 m BE-Boom	9.1 m		
	Arm length	3.4 m BE-Arm	3.4 m	4.5 m	5.8 m
A	Max. digging reach	13 760	15 340	16 380	17 360
A'	Max. digging reach (on ground)	13 380	15 000	16 070	17 070
B	Max. digging depth	7 940	9 340	10 420	11 420
B'	Max. digging depth (8' level)	7 820	9 210	10 310	11 330
C	Max. cutting height	12 300	13 490	14 020	14 400
D	Max. dumping height	8 020	8 920	9 430	10 360
E	Max. vertical wall depth	5 080	7 620	8 880	10 360

All dimensions are in mm.

Bucket digging force	kgf	56 100	46 600	46 600	33 200
Arm crowd force	kgf	42 000	41 900	33 700	29 300

Buckets

Capacity	Width		No. of teeth	Weight	Type	Materials density kg/m ³			
	Without shroud	With shroud				BE-front			
						7.55 m BE-boom 3.4 m BE-arm		9.1 m boom	
						3.4 m arm	4.5 m arm	5.8 m arm	
5.0 m ³	1 860 mm	1 960 mm	5	5 460 kg	●	1 800			
5.6 m ³	2 020 mm	2 121 mm	5	6 540 kg	●	1 800			
6.0 m ³	2 106 mm	2 206 mm	6	6 172 kg	○	2 100			
6.5 m ³	2 210 mm	2 310 mm	6	6 769 kg	○	1 800			

- Rock bucket
- General purpose bucket

BE-front with 5.6m³ Rock Bucket

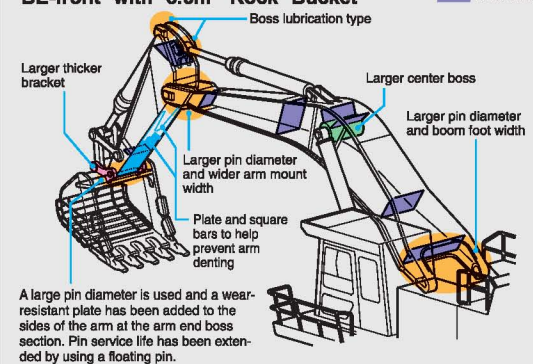

Specifications

Standard Equipment

Monitor Systems

• Meters:

Hourmeter and trip-meter, engine coolant temperature gauge and fuel gauge, auto-idle, quick-idle indicator.

• Warning indicators:

Radiator water level, engine oil level, hydraulic oil level, fuel level, auto lubrication, air-filter restriction, pump transmission oil pressure, alternator, exhaust temperature, over heat, engine oil pressure, engine stop, work light, preheat, and engine warmup.

• Hour meter and trip-meter select switch

• Reset switch

Data Logging System

• DLU (Data Logging Unit)

Continuously records performance of the engine and the hydraulic systems. The record can be down-loaded by a laptop computer.

Superstructure

• Undercover

• 17 500 kg counterweight

• Control valves with main relief valves and port relief valves

• Slow return orifices and make up valves for cylinder circuits

Undercarriage

• Spring-set/hydraulic-released disc type parking brake

• Hydraulic (grease) track adjuster with shock absorbing recoil spring

• Travel motor cover

• Track and idler guards.

Miscellaneous

• Standard tool kit; ISO-meeted stairs and handrails; Wide side walk; 12 V power terminal board; Slip resistance tapes; Elevated Cab (for Loading Shovel)

Optional Equipment

• High cab kit (for Backhoe); Full track guard; Fire suppression system; Auto-lubrication system for front-attachment.

Loading Shovel Attachments.

Boom and arm are all-welded, low-stress, high-tensile strength steel full-box section design. Efficient, automatic level crowding achieved by one-lever control because parallel link mechanism keeps the bucket digging angle constant, and level cylinder circuit maintains the bucket height constant. (Auto-leveling Crowd Mechanism)

Working Ranges

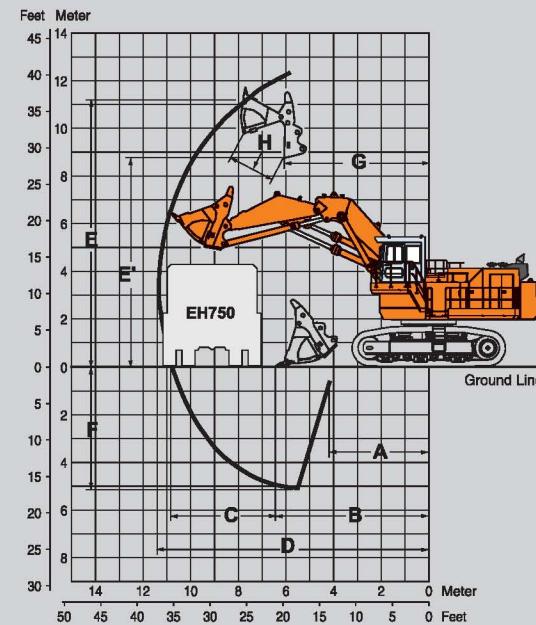

- Dual-support-type boom/arm/bucket pin linkage
- Double lip pin seals plus O-ring with protector ring at arm top.

		Boom dump type
A	Min. digging distance	4 460
B	Min. level crowding distance	6 520
C	Level crowding distance	4 340
D	Max. digging reach	11 440
E	Max. cutting height	12 350
E'	Max. dumping height	8 740
F	Max. digging depth	5 240
G	Working radius at max. dumping height	6 090
H	Max. bucket opening width	1 880

All dimensions are in mm.

Crowding force	59 400 kgf
Breakout force	60 100 kgf

Bucket (PCSA Heaped 2:1)

Capacity	Width	No. of teeth	Weight	Type
5.9 m ³	2 500 mm	6	9 910 kg	-
6.5 m ³	2 700 mm	6	9 960 kg	*

- Bottom dump type rock bucket
* Bottom dump type general purpose bucket

Devices for Safety

Strong Undercarriage

Giant Undercarriage

Forming the base for powerful operation, the large undercarriage, 4 610 mm wide and 6 410 mm long, provides stability.



Rugged Travel Device

Damage-resistant travel device keeps the giant moving. The shape of the frame has been changed and thicker steel plates have been used to boost durability and reduce downtime from damage.

Track Center Frame

Built for high reliability. The mounting section for the track center frame swing gear has an integral cast steel design to reduce the concentration of stress forces, thereby boosting reliability.

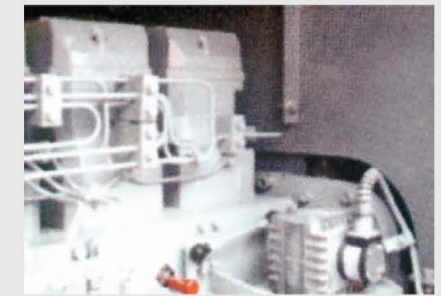
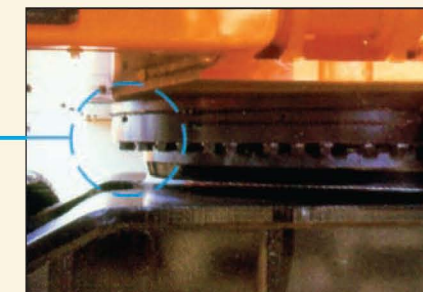
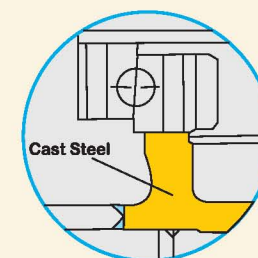

Pump bulkhead



Operator's seat



Right window guard



Pilot-control shutoff lever

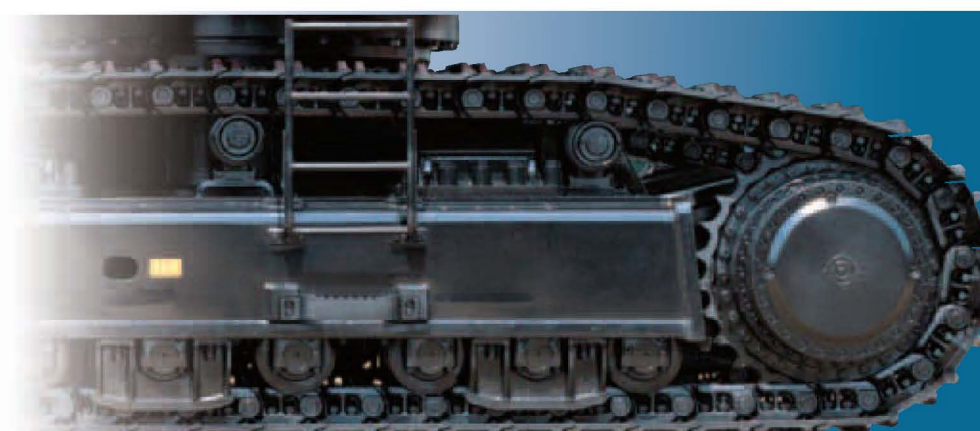

Easy Maintenance - Reduces Total Lifetime Cost

Easy Inspection & Maintenance

Wide access helps speed essential inspection time and reduce maintenance costs. Key components have been centrally positioned and walkways have been provided to make inspections and maintenance as easy as possible

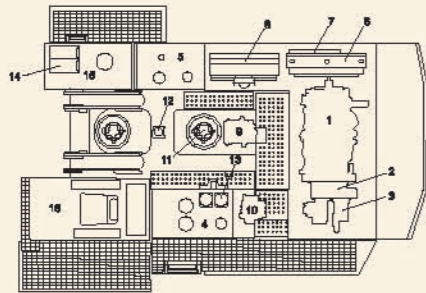

- | | | |
|----------------------|------------------------|---------------------------------|
| 1 Engine | 6 Engine Radiator | 11 Swing Device x 2 |
| 2 Pump Drive Unit | 7 Engine Air Cooler | 12 Center Joint |
| 3 Hydraulic Pump x 3 | 8 Oil Cooler | 13 Filters |
| 4 Hydraulic Tank | 9 Main Control Valve | 14 Batteries |
| 5 Fuel Tank | 10 Swing Control Valve | 15 Batteries and Lubricator box |
| | | 16 Operator Cab |

Centre walkway



Tool box space

Radiator & Oil Cooler

Designed for easy cleaning.

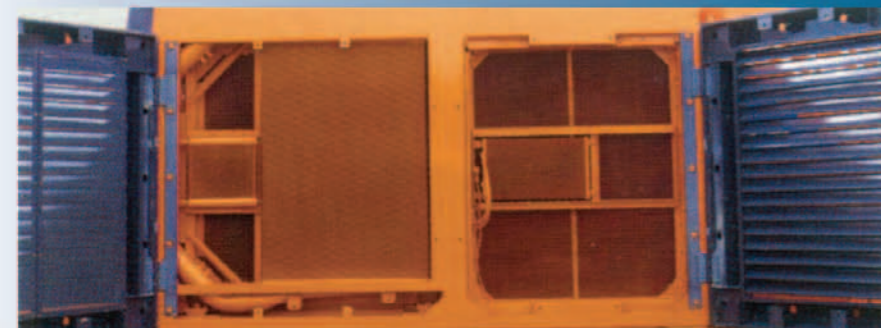

High Cab

(Optional for Backhoe)



Auto-Grease Lubricator

(Optional)

Reduces the time and effort needed for lubrication.

It dramatically reduces the work required for lubrication. (Does not lubricate the bucket area or the swing gear.)

Longer Filter Life

Reduces the overall time and expense for replacement.

The service life of the engine oil filter and the fuel filter have been increased to 500 and 1,000 hours respectively.

Wide Inspection Doors

Easy access to engine and pump compartments.



The inspection doors open wide to provide easy access to the engine and pump compartments.

Specifications

Undercarriage

Tracks

Tractor-type undercarriage. Bolt linkage for side frame assures durability. Heavy-duty track frame of all-welded, stress-relieved structure. Top-grade materials used for toughness. Lifetime-lubricated induction-hardened track rollers, idlers and sprockets with floating seals. Track shoes with double grousers. Double strut reinforced track links with track guards. Hydraulic (grease) track adjusters with shock absorbing recoil springs.

Tractor-type Undercarriage

Double grouser track shoes of induction-hardened cast steel.

Shoe width	710 mm Standard
Shoe width	900 mm optional for Backhoe attachment only

Number of Rollers and Shoes (each side)

Upper Rollers	3
Lower Rollers	8
Track Shoes	52

Traction Device

Each track driven by a high-torque, axial piston motor through planetary reduction gears, allowing counter rotation of the tracks. Easily replaceable sprockets. Parking brake of spring-set, hydraulic-released disc type.

Travel speeds	Low: 0 to 2.5 kmph
	High: 0 to 3.6 kmph
Maximum traction force	63 000 kgf
Gradeability	35° (70%) max.

Weights and ground pressure

Backhoe

EX1200-V : Equipped with 9.1 m boom, 3.4 m arm, and 5.0 m³ (PCSA heaped) bucket.

Shoe type	Shoe width	Operating Weight	Ground Pressure
Double Grousers	710 mm	108 000 kg	1.39 kgf/cm ²
	900 mm	110 000 kg	1.11 kgf/cm ²

EX 1200-V BE-front: Equipped with 7.55 m BE-boom, 3.4 m BE-arm, and 6.5 m³ (PCSA heaped) bucket.

Shoe type	Shoe width	Operating Weight	Ground Pressure
Double Grousers	710 mm	109 000 kg	1.40 kgf/cm ²
	900 mm	111 000 kg	1.12 kgf/cm ²

Leading Shovel

Equipped with 6.5 m³ (PCSA heaped) bottom dump bucket.

Shoe type	Shoe width	Operating Weight	Ground Pressure
Double Grousers	710 mm	111 000 kg	1.40 kgf/cm ²

Service Refill Capacities

	Litres
Fuel tank	1 400
Engine coolant	113
Engine oil	70
Pump drive	15
Swing device (each side)	25
Travel final device (each side)	43
Hydraulic tank	610
Hydraulic system	1350

Standard Equipment

Engine

- S/P mode control
- E mode control
- 75A - alternator
- Dry-type air filter with clean dust cup
- Cartridge-type fuel filter
- Water filter
- Radiator and air cooler with dust protective net
- Radiator reserve tank
- Fan guard
- Isolation-mounted engine
- Auto-idle system
- Quick-idle system
- Overheat prevention device

Hydraulic System

- E-P control system
- OHS (Optimum Hydraulic System)
- FPS (Fuel-saving Pump System)
- Heavy lifting system
- Boom mode selector system
- Forced-lubrication and forced cooling, pump drive system
- Control valve with main relief valve
- Suction filter
- Full-flow filter
- Pilot filter
- Pump drain filter

Cab

- All-weather sound-suppressed steel integrated cab with headguard (meeting SAE FOPS).
- Intermittent wiper interlocked with front windshield washer.
- Footrest
- Electrical Horn
- Floor mat
- Engine control dial
- Pilot control shut-off lever
- Air Conditioner

Lights

- 2 Head lights, 2 Cab lights
- 1 Entrance light

Specifications

Engine

Model Cummins QSK23-C
 Type Water-cooled, 4 cycle, 6-cylinder
 In line, turbo-charged direct injection
 chamber-type diesel engine.

Rated power
 DIN 6271, net 538 kW (731 PS)
 at 1 650 min⁻¹ (rpm)
 SAE J1995, gross 567 kW (760 HP)
 at 1 650 min⁻¹ (rpm)
 Piston displacement 23.15 L (1 412 in³)
 Max. Torque 3580 N-m@1350 (rpm)

Hydraulic System

Hitachi's ETS (Electronic Total Control System) can achieve maximum job efficiency by reducing fuel consumption and noise levels, while maximising productivity through the optimization of engine- pump functions with excellent controllability increasing operator comfort.

- E-P Control (Computer-aided Engine-Pump Control system) Main pumps regulated by electronic engine-speed sensing control system. Optimum operation mode selectable among 3 power modes depending on type of job.
- OHS (Optimum Hydraulic System assures fully independent and combined operations.
- FPS (Fuel-saving Pump System)
- Auto-idling system.
- Quick-auto-idling system.
- High-pressure 2-speed travel system for high traction force and travel speed.
- Forced-cooling pump drive system.
- TIG (Tungsten Inert Gas) welding pipings.

Main pumps 3 Variable-displacement, swash
 plate type axial piston pumps
 Maximum Oil flow 3 x 495 L/min
 Pilot pump Gear Pump
 Maximum oil flow 63.0 L/min

Relief Valve Settings

Implement circuit 320 kgf/cm²
 Swing circuit 300 kgf/cm²
 Travel circuit 320 kgf/cm²
 Pilot circuit 40 kgf/cm²

Hydraulic Filters

All hydraulic circuits have high-quality hydraulic filters for protection against oil contamination and longer life of hydraulic components.

	Qty.	
Full Flow filter	2	10 μm
Drain filter	1	10 μm
(For all plunger type pumps & motors)		
Suction filter	2	177 μm
Pilot filter	1	10 μm

These filters are centralized in arrangement for facilitating maintenance.

Hydraulic Cylinders

High-strength piston rods and tubes adopted. Cylinder cushion mechanisms are provided for boom, arm, bucket and dump cylinders. Bucket cylinder of loading shovel is provided with protector.

Booms

	Qty	Bore	Rod Diameter
Boom	2	230	160
Arm	1	260	180
Bucket	1	230	160

All dimensions are in mm.

Shovel

	Qty	Bore	Rod Diameter
Boom	2	230	160
Arm	1	215	150
Bucket	2	200	150
Dump	2	140	85
Level	1	230	160

All dimensions are in mm.

Controls

2 Implement Levers

Remote-controlled joystick hydraulic servo system. Right lever is for boom and bucket control, left lever for swing and arm control. For loading shovel, 2 pedals provided for opening/closing the bottom dump bucket

2 Travel Levers with pedals

Remote-controlled hydraulic servo system. Independent drive at each track allows counter rotation of tracks.

Superstructure

Revolving Frame

A deep, full-reinforced box section. Heavy-gauge steel plates used for ruggedness.

Swing Mechanism

2 high-torque, axial-piston motors with planetary reduction gear bathed in oil. Swing circle is single-row, shear-type ball bearing with induction-hardened internal gear. Internal gear and pinion gear immersed in lubricant. Swing parking brake is spring-set, hydraulic-released disc type.

Swing speed 5.8 min⁻¹ (rpm)

Operator's Cab

Steel construction with integrated, falling-object-protective structure (meeting SAE FOPS). Independent, pressurized, 1 100 mm wide, 1 900 mm high, roomy 3.46 m³ cab with glass windows features all-round visibility. Spring-suspension-type, fully-adjustable reclining seat with armrests; movable with or without front and swing control levers by slide. Instrument and control panel is built in cab wall and within easy range of the operator. Air conditioner is standard. Fluid-filled elastic-mounting and sound-proofing structure to reduce noise level and vibration.

Data Logging System

DLU (Data-logging unit) continuously records performance of the engine and the hydraulic systems. The record can be downloaded by PC.

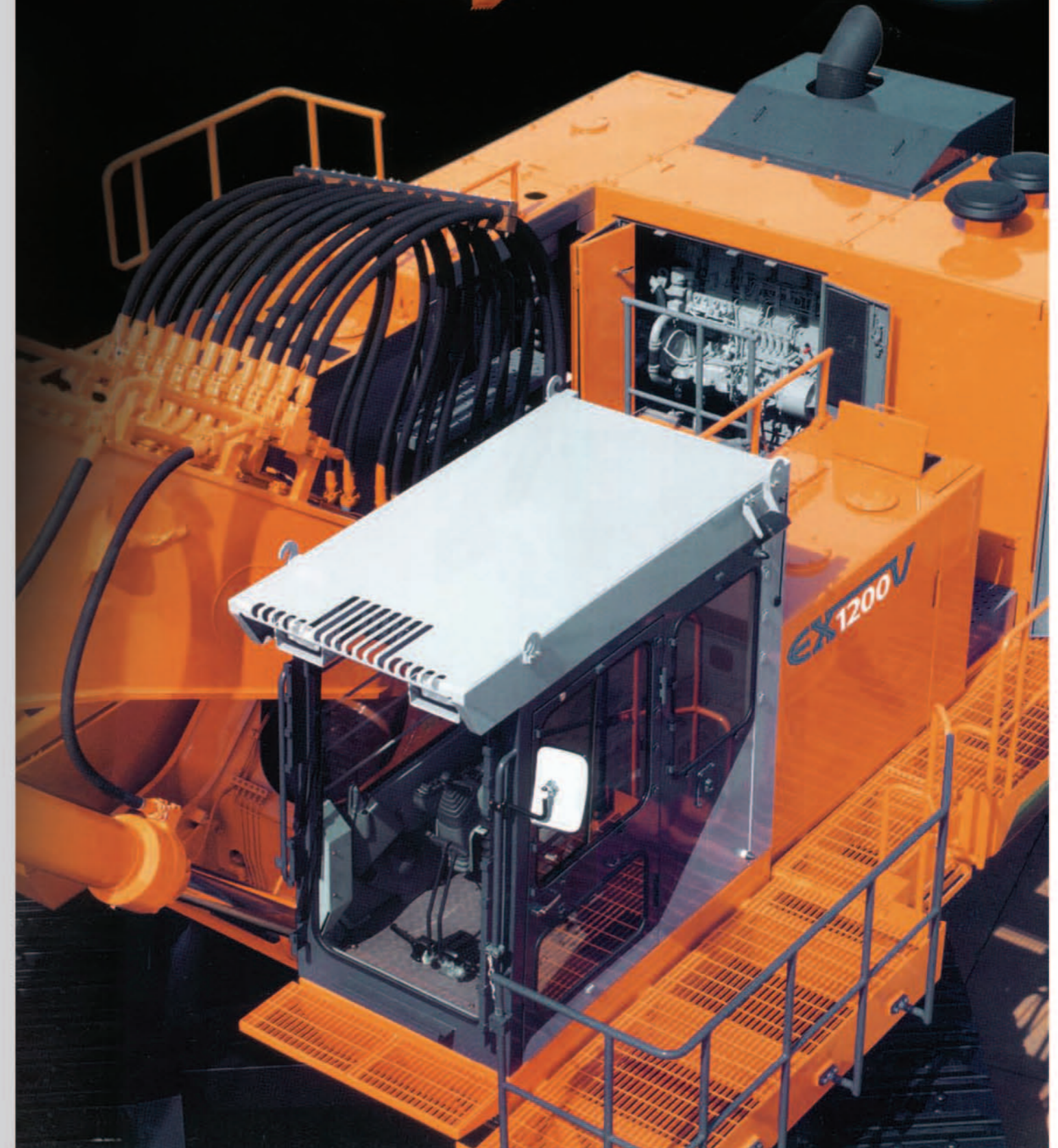
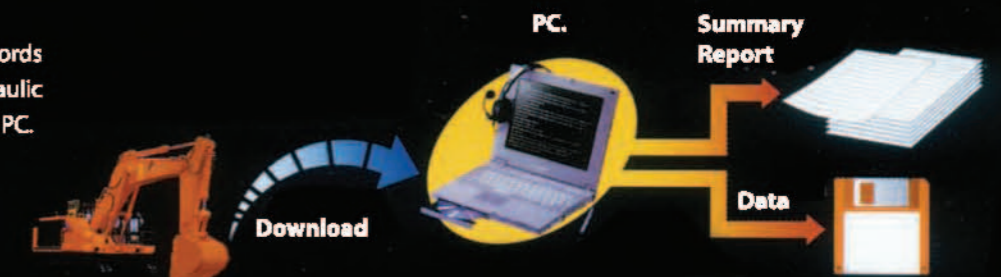

Uncompromising Safety

Rugged Pressurized Cab with Integrated Headguard

Offers solid protection to the operator. The operator's cab meets strict ISO Operator Protective Guards (OPG) standards*. The cab structure is formed from an integral internal frame that is designed to resist operating vibration. It stands ready to protect the operator from falling objects. (*Front guard is optional.)



Wide Sidewalks and Large Handrails

Wide sidewalks with handrails are provided at key locations for easy access to the cab and simplified servicing. Handrails conform to EN (European Norm), a world-class safety standard.



Adjustable Headlights

Provides bright illumination where it is needed. The headlights above the cab can be adjusted downward to shine light on the work area.



Step Light



Transportation Weights of Major Components

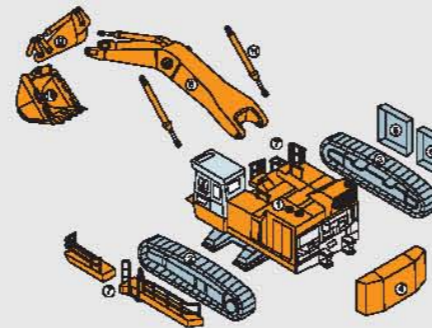

Major Components	
1. Main frame assembly: backhoe	33 900 kg
: loader front	34 500 kg
2. Truck side frame assembly: left	14 600 kg
3. : right	14 600 kg
4. Counterweight	17 500 kg
5. Radiator cover	93 kg
6. Oil cooler cover	85 kg

Backhoe	
7. Sidewalk assembly: left	470 kg
Sidewalk assembly: right	181 kg
8. Boom assembly: 9.1 m boom	9 690 kg
: 7.55 m BE - boom	9 080 kg
9. Arm assembly: 3.4 m arm	5 970 kg
: 3.4 m BE - arm	6 100 kg
10. Bucket assembly: 5.0 m ³	4 480 kg
: 6.5 m ³	6 350 kg
11. Boom cylinders	1 170 kg x 2

Loading shovel	
• Sidewalk assembly	578 kg
• Boom and Arm assembly	15 200 kg
• Bucket assembly: 6.5 m ³	9 200 kg
• Boom cylinders	1 170 kg x 2

Productive Comfort

Cab Size, a 10% increase. (compared to EX 1100-3)

Large Comfortable Cab

Provides comfort to reduce operator fatigue. The cab is 10% larger than the previous model to provide an even higher level of comfort. It has been designed to offer clear visibility of the work area. Fluid-filled elastic mounts help reduce fatigue-causing vibration.

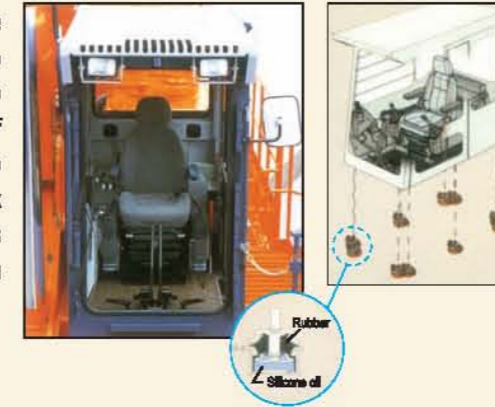

Air conditioner

Keeps the operator's cab at a comfortable temperature.



One-Glance Instrument Panel

Positioned within natural line of sight. Instrument panel is positioned so that all key-operating conditions can be monitored with just a glance.



Well-positioned Levers and Switches

Levers and switches are near the operator to reduce the need to reach for them.

The levers and switches have been strategically located to reduce the amount of operator movement required to operate them. Frequently used switches have been centralized at a location next to the operator.

Boom Mode Selector

Helps to reduce shaking and jerking of body during scraping operations. The amount the body can be lifted or pulled by the front of machine can be selected. This helps to provide for more comfortable operation and contributes to longer component service life.



ON Comfortable mode

There is a little lifting or pulling of the body so there is less vibration and shock.

OFF Powerful mode

Much lifting and pulling of the body so there is more vibration and shock.

