

8. INSTALLATION/WIRE CONNECT GUIDE

Before Starting

1. This set is exclusively for use in cars with a negative ground, 12 V power supply.
2. Read these instructions carefully.
3. Be sure to disconnect the battery "⊖" terminal before starting. This is to prevent short circuits during installation. (Figure 1)

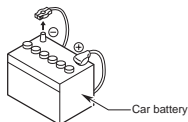

Figure 1

Package Contents

Main unit	1	Strap	1
Owner's manual & Installation manual	1	Parts bag	1
Power extension lead	1	• Hexagonal bolt	1
Mounting bracket	1	• Removal key	2
Outer escutcheon.....	1	• Stopper.....	1

General Cautions

1. Do not open the case. There are no user serviceable parts inside. If you drop anything into the unit during installation, consult your dealer or an authorized Clarion service center.
2. Use a soft, dry cloth to clean the case. Never use hard cloth, thinner, benzene, alcohol, etc. For tough dirt, apply a little cold or warm water to a soft cloth and wipe off the dirt gently.

Cautions on Installation

1. Prepare all articles necessary for installing the main unit before starting.
2. Install the unit within 30° of the horizontal plane. (Figure 2)
3. If you have to do any work on the car body, such as drilling holes, consult your car dealer beforehand.
4. Use the enclosed screws for installation. Using other screws can cause damage. (Figure 3)

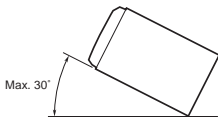

Figure 2

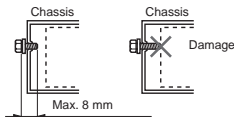

Figure 3

Installing the Main Unit

1. Place the universal mounting bracket into the instrument panel, use a screwdriver to bend each stopper of the mounting bracket inward, then secure the stopper. (Figure 4)
2. Wire as shown on page 29.
3. Insert the main unit into the universal mounting bracket.
4. Mount the outer escutcheon so that all the hooks are locked. (Figure 7, 8 on page 28)

Notes:

- Some car models require special mounting kits for proper installation. Consult your Clarion dealer for details.
- Fasten the front stopper securely to prevent the main unit from coming loose.

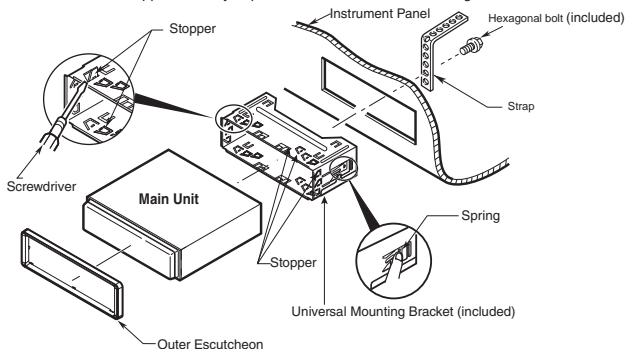
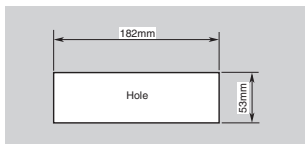

Figure 4

- Console opening dimensions



CAUTION

PRECAUTION

Push in the protruding part (STOPPER) as shown in the Figure 5. When this main unit is installed without the universal mounting bracket.

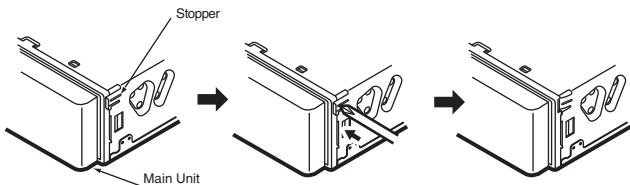

Figure 5

Fixed Mount (Using the bracket originally equipped in vehicle)

If the vehicle is equipped with a factory-installed radio, install the main unit with the parts and screws marked (★). (Figure 6)

If the vehicle is not equipped with a factory-installed radio, obtain an installation kit to install the main unit in the following procedure.

1. Secure the mounting brackets to the chassis as shown in Figure 6. When the main unit is installed without the universal mounting bracket, holes exist; modification, such as drilling new holes, of the mounting brackets may be required for other models.
2. Wire as shown in Installation (page 29).
3. Secure the unit in the dashboard, and then reassemble the dashboard and the center panel.

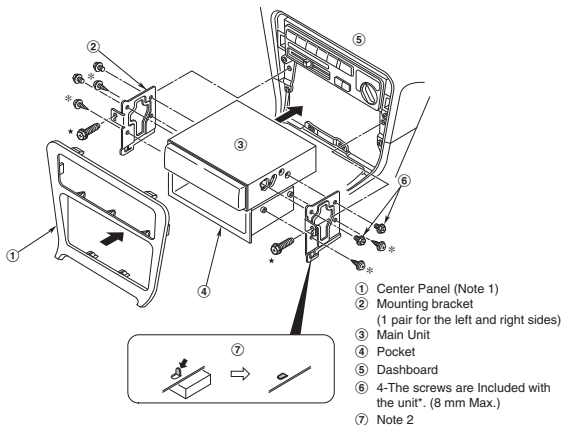

Figure 6

* : The screws with this mark are included with the unit. (Note 3).

★ : The screws with this mark are originally attached to the vehicle.

Note 1:

- In some cases, the center panel may require some modification (trimming, filling, etc.).

Note 2:

- If a hook on the installation bracket interferes with the unit, bend and flatten it with a nipper or a similar tool.

Note 3:

- If reattaching screws which have been detached, remove any filings from the screws and screw mounting bracket.

Removal

1. Remove the Detachable Control Panel (DCP). For instructions on removing the DCP, refer to the owner's guide.
2. Press the outer escutcheon upward and remove it. (Figure 7)
3. Insert and lock the hook plates. (Figure 8)
4. Pull the hook plates to remove the main unit.

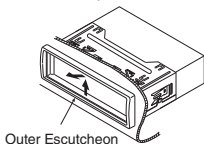

Figure 7

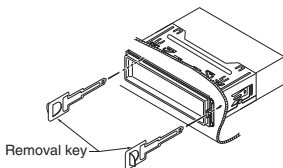

Figure 8

Cautions on Wiring

1. Be sure to turn the power off when wiring.
2. Be particularly careful where you route the cables. Keep them well away from the engine, exhaust pipe, etc. Heat may damage the wires.
3. If the fuse should blow, check that the wiring is correct. If it is, replace the fuse with a new one with the same amperage rating as the original one. (Figure 9)
4. When the main power supply fuse in the car is 15 A or less, purchase an automotive cable that can withstand 15 A and supply this unit with power directly from the battery to ensure that the unit will operate normally. Note that a fuse must be installed at a distance no longer than 30 cm from the cable battery terminal to prevent accidents.

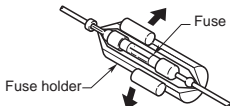

Figure 9

Wire Connections

CAUTION:

- Please make sure when connecting external power amplifier, that you properly, to the car chassis, ground the amplifier. If this is not done, severe damage to the main unit may happen.
- External microphone has to be connected at the back of the main unit during installation if necessary.
- By connecting optional external microphone, internal microphone is canceled automatically.

